

Date: May 31, 2021

Notice of Specification Change

Notice of Specification Change(s):

TPM would like to inform you that a specification change is required from 102-M141-YS5 and 102-M141-YS5B.

- Function selector added.

Current Specifications: 102-M141-YS5 and 102-M141-YS5B

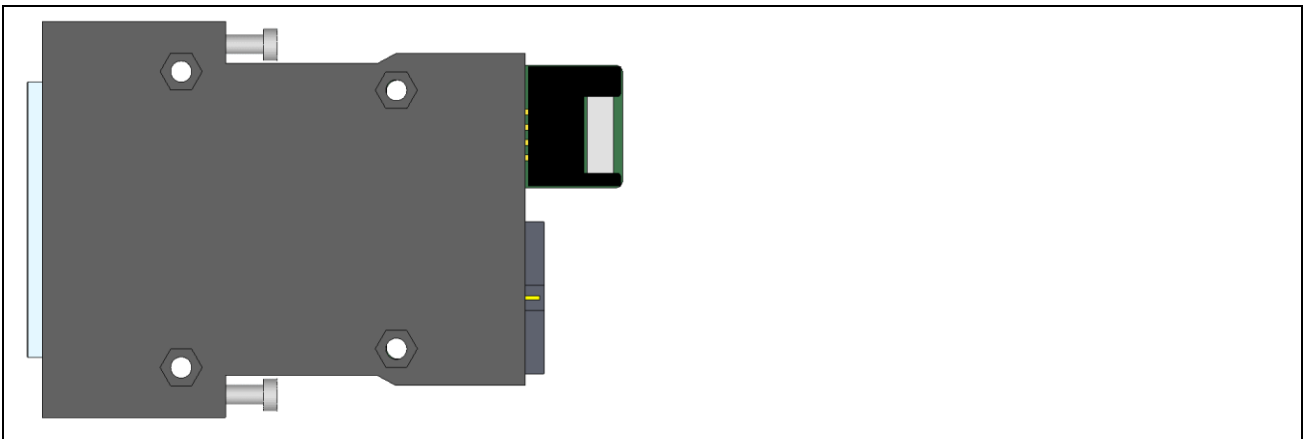

Updated Specification: Combine two model in one model “102-M141-YS5”

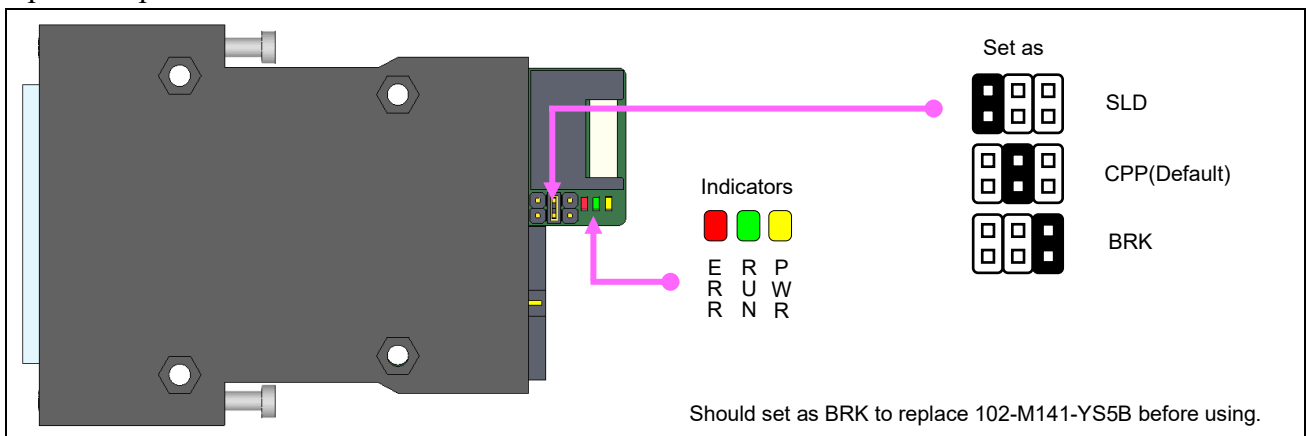

Sincerely,

TPM Project Team

project.tpm@tpm-pac.com